

# On the Road to Stewardship ICOET 2005

August 29-September 2, 2005  
San Diego, California

## 2005 Proceedings



International Conference  
on Ecology & Transportation

# Acknowledgments

This proceedings was published by the Center for Transportation and the Environment (CTE), located at the Institute for Transportation Research and Education (ITRE) at North Carolina State University (NCSU), with funding support from the Federal Highway Administration (FHWA), U.S. Forest Service (USDA-FS), U.S. Fish and Wildlife Service (USFWS), U.S. Environmental Protection Agency (USEPA), Washington State Department of Transportation (WashDOT), Florida Department of Transportation (FDOT), Humane Society of the United States, and Defenders of Wildlife.

CTE thanks the following for their assistance with this publication:

- C. Leroy Irwin, ICOET 2005 conference chair; Dr. Paul Garrett, FHWA senior ecologist and ICOET 2005 program committee chair; and the members of the ICOET 2005 steering and program committees – whose hard work and dedication to the evolving field of transportation and ecology generated an outstanding technical program, the results of which are reflected in the contents of this document.
- The California Department of Transportation (most especially Sheila Mone) and the University of California at Davis Road Ecology Center (most especially Dr. Alison Berry) – who co-hosted the conference and designed a special session on acoustics ecology, a new topic for the conference and for this proceedings.
- Neil Koomen and Jason Lundberg of CTE, and Lisa Gullette and Kate Trapp of ITRE's Communications Office – who worked tirelessly and enthusiastically with the authors to prepare their manuscripts for publication, in addition to coordinating the numerous production tasks associated with this document's design and layout, copyediting, printing, and distribution.
- Finally, and most importantly, to all the authors, who in contributing their work to this conference proceedings have expanded significantly the body of knowledge on wildlife, habitat, and ecosystem issues related to the delivery of surface transportation systems.

## **Bibliographic Citation**

Please use the following format to cite works from this proceedings:

[Author last name, first name]. ["Title of Paper"]. In *Proceedings of the 2005 International Conference on Ecology and Transportation*, edited by C. Leroy Irwin, Paul Garrett, and K.P. McDermott. Raleigh, NC: Center for Transportation and the Environment, North Carolina State University, 2006.

## **Cost Statement**

500 copies of this public document were printed for a total cost of \$6,790 or \$13.58 per copy.

## **To Order Additional Copies**

Additional copies of this document may be ordered through CTE for \$25 per copy (includes shipping and handling). A keyword-searchable CD-ROM version is also available free of charge upon request while supplies last. To order, please call CTE at (919) 515-8893 or email your request to [cte\\_email@ncsu.edu](mailto:cte_email@ncsu.edu).

A keyword-searchable Adobe Acrobat PDF version of the proceedings is also available on the conference Web site at [www.icoet.net](http://www.icoet.net).

© 2006 Center for Transportation and the Environment, North Carolina State University. All rights reserved.

This publication may be reproduced in whole or in part for non-profit educational purposes provided that credit is given to the author(s) and to the Center for Transportation and the Environment, North Carolina State University.

ISBN: 0-9778094-1-2

# RELIABILITY OF THE ANIMAL DETECTION SYSTEM ALONG US HWY 191 IN YELLOWSTONE NATIONAL PARK, MONTANA, USA

**Marcel P. Huijser** (Phone: 406-543-2377, Email: [mhuijser@coe.montana.edu](mailto:mhuijser@coe.montana.edu)), **Whisper Camel**, and **Amanda Hardy**, Western Transportation Institute, Montana State University, P.O. Box 174250, Bozeman, MT 59717-4250

**Abstract:** Animal detection systems use high-tech equipment to detect large animals when they approach the road. Once a large animal is detected, warning signs are activated urging drivers to reduce their vehicle speed, be more alert, or both. Lower vehicle speed and increased alertness may then lead to fewer and less severe collisions with, for example, deer (*Odocoileus sp.*), elk (*Cervus elaphus*), or moose (*Alces alces*). For this study, we investigated the reliability of the animal detection system installed along US Hwy 191 in Yellowstone National Park, Montana, USA. The system was designed to detect elk and stored all detection data, including the detection zone in which the detection occurred, and a date and time stamp. Interpretation of the detection data suggested that at least 47 percent of all detections were related to animals crossing the road. However, animals walking in the right-of-way or medium-sized mammals (e.g., coyotes, *Canis latrans*) do not generate a clear detection pattern, and were, therefore, classified as "unclear." Therefore, the 47 percent should be regarded as a minimum estimate. The timing and direction of travel of crossing events, indicated by detections on opposite sides of the road, matched local knowledge about the behavior of the elk, suggesting that the system was able to detect large animals, specifically elk, and that the data were interpreted correctly. We also compared the spatial distribution of the crossing events with snow tracking data. The spatial distribution of the crossing events and elk tracks showed a close match, again suggesting that the system was able to detect elk, and that the data were interpreted correctly. Almost 87 percent of all elk crossings recorded through snow tracking could be linked to a crossing event detected by the system. However, medium-sized mammal species, such as coyotes and wolves (*Canis lupus*), were not or rarely detected. Furthermore, we identified the presence and location of blind spots (potentially 17.8% of the total length covered by the sensors). Blind spots were defined as locations where the system failed to detect a human crossing between the sensors. Most of the blind spots were due to curves and slopes that caused the detection beam to shoot too high above the ground. The total time for which the flashing warning lights would have been activated was estimated at one hour and 13 minutes per day, a marked difference compared to permanently activated warning signs. Most crossing events (72.6%) were completed within three minutes, and the median duration of a crossing event was one minute and 29 seconds. If the warning signs would be activated for three minutes after the last detection, the signs would have been continuously activated for 88.1 percent of all detection intervals (i.e., time between consecutive detections) during crossing events. Similarly, 78.1 percent of all crossing events would have had the warning signs continuously activated while the crossing was in process. We conclude that the system reliably detects large animals, especially elk, but the system does not detect all elk that cross the road, e.g., because of blind spots. In addition, a three-minute activation period for the warning signs appears to be a good balance between keeping the signs turned on while elk are in the process of crossing the road, and not presenting drivers with activated warning signs longer than necessary.

## Introduction

Animal detection systems use high-tech equipment to detect large animals when they approach the road. Once a large animal is detected, warning signs are activated urging drivers to reduce their vehicle speed, be more alert, or both. Lower vehicle speed and increased alertness should then lead to fewer and less severe collisions with, for example, deer (*Odocoileus sp.*), elk (*Cervus elaphus*), or moose (*Alces alces*).

There are about 30 locations throughout Europe and North America that have or had an animal detection system in place (Huijser and McGowen 2003, Huijser and McGowen in prep.). Data on the effectiveness of animal detection systems are scarce, but data from Switzerland suggest that animal detection systems may lead to an 82-percent reduction in the number of ungulate-vehicle collisions (Kistler 1998, Romer and Mosler-Berger 2003, Mosler-Berger and Romer 2003). Nonetheless, in order for such systems to be effective, they must first detect large animals reliably. Few studies have documented such reliability data (e.g., Gordon et al. 2001, Kinley et al. 2003).

In this study, we investigate the reliability of the animal detection system installed along US Hwy 191 in Yellowstone National Park, Montana, USA. In addition, we investigate the characteristics of crossing events detected by the system to evaluate the period of time for which the warning signs should be activated once a large animal is detected.

## Methods

### Study site

In October and November 2002 an animal detection system was installed along US Highway 191 in Yellowstone National Park, between West Yellowstone and Big Sky, Montana, USA. The system was installed along a 1.6-km (1 mi) road section (mile posts 28.0-29.0) (figure 1). This two-lane road is located in a valley and runs parallel to the Gallatin River. Adjacent mountain slopes are mostly forested while the valley is dominated by grasslands and shrubs along the river banks. However, the north side of the road section with the animal detection system (detection zones E, B, C, 4 and 7, see figure 1) has trees (mostly lodgepole pine, *Pinus contorta*) on both sides of the road within 9 m (30 ft) from the pavement. The rest of the road section is more open and has steep slopes, especially on the west side of the road.

The lands on the east side of the river, where the road section with the animal detection system is located, are part of Yellowstone National Park. The lands on the other side of the river are mostly National Forest Service lands. A section of private land, the Black Butte Ranch, is located adjacent to part of the study site on the west side of the river. The access road to the ranch connects to US Hwy 191 about midway in the road section with the animal detection system

(figure 1). A parking area for a trailhead is located on the west side of the road, about 600 m (0.37 mi) farther to the north. The trail itself starts on the east side of the road. Furthermore, there is a pullout on the west side of the road about 150 m (493 ft) south of where the access road to the ranch connects with US Hwy 191. The elevation of the site is about 2,073 m (6,800 ft), and annual average snowfall is about 305 cm (120 in). Winter driving conditions include heavy snowstorms and an icy and snow-packed road surface with heavy winds and temperatures well below -30 °C (-22 °F).

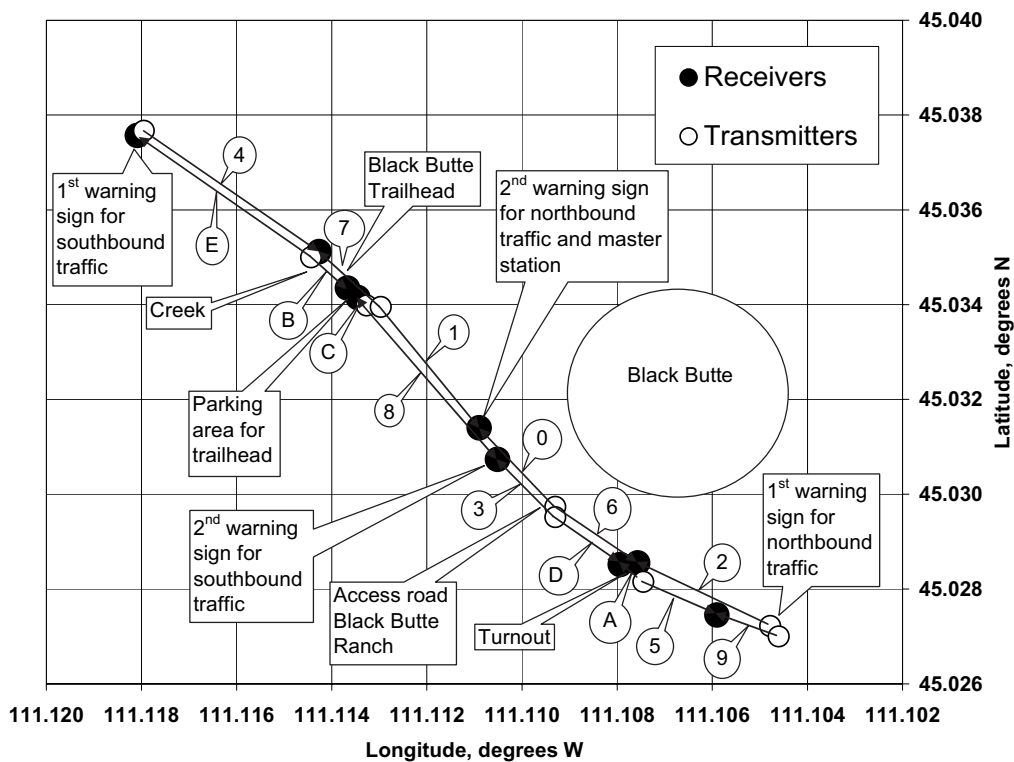

Figure 1. Schematic layout of the animal detection system and major road and landscape features at the study site (Source: STS). The numbers and letters represent the codes of the individual detection zones.

US Hwy 191 has two lanes that are 3.7 m (12 ft) wide with asphalt road surface. The shoulder width varies between 0.6-1.2 m (2-4 ft). The clear zone is usually 6.1 m (30 ft) wide, but steep slopes are closer to the road along certain sections. The right-of-way on the west side of the road has a steep slope for about 500 m (0.31 mi). The road has some curves within the section with the animal detection system. The speed limit is 88 km/h (55 mi/h), but the average vehicle operating speed is around 113 km/h (70 mi/hr) (Gunther et al. 1998; speed readings by WTI-MSU, November 2002). The average annual daily traffic volume (AADT) is about 2,545 vehicles with about 13 percent truck traffic (estimated in 2000). Traffic volume peaks in July (4400 ADT), mostly because of tourists that visit the area.

The area is home to many large mammal species including elk, moose, bison (*Bison bison*), mule deer (*Odocoileus hemionus*), white-tailed deer (*O. virginianus*), black bears (*Ursus americanus*), grizzly bears (*U. Arctos*), coyotes (*Canis latrans*), and wolves (*C. lupus*). The majority of the recorded animal-vehicle collisions in this area involve elk (table 1).

Table 1. Number of recorded road-killed large animals between 1989 and 1998 at and adjacent to the road section with the animal detection system (Source: Yellowstone National Park)

Mile marker	Total recorded road kill	Moose	Elk	Mule deer	Black bear	Wolf	Coyote	Beaver	Raccoon
27-28	38	0	30	4	0	0	2	2	0
28-29	67	2	56	2	0	1	5	0	1
29-30	29	1	21	1	1	1	4	0	0

The valley and surrounding slopes are an important wintering area for elk, and most elk-vehicle collisions occur during the winter season (Source: Montana Department of Transportation; Yellowstone National Park). However, the number of elk wintering in the valley and along US Hwy 191 and the number of elk-vehicle collisions may have decreased during the last several years (Pers. com. Russel Rooney, Montana Department of Transportation). It may be that this

reflects a true decrease in population size, but it is also possible that the elk are more dispersed than before, perhaps because of the presence of wolves in the area (White and Garrott 2005). Currently, most of the elk seem to move across the road in the fall (November-mid December) when they migrate to lower elevation areas, and in the spring (mid March-mid May) when they migrate to higher elevation areas as the snow melts off. Elk that spend the winter along the Gallatin River and the surrounding slopes typically spend the day bedded down on the forested slopes (Pers. com. Greg and Sara Knetge, caretakers Black Butte Ranch). In the evening the elk travel down the slopes to the valley bottom to forage on grasses and shrubs along the river. In the early morning hours they move up the slopes again. Hence, there seems to be a concentration of elk crossing the road in the evening and early morning.

### **Animal detection system**

The animal detection system was manufactured by Sensor Technologies and Systems (STS), Scottsdale, Arizona, USA. After installation (October-November 2002), the system experienced a range of technological challenges, and it was not until November 2004 that the system appeared to function as originally intended (Salsman and Wilson in prep.).

The system is based on a “break-the-beam” principle (see Huijser and McGowen, 2003). This break-the-beam system consists of transmitters that send modulated low-power microwave radio signals (around 35.5 GHz) to receivers. When an animal’s body breaks the beam, the receiver signal output is decreased, indicating a detection. The paired transmitters and receivers (sensors) cover 1,609 m (1 mi) along both sides of US Hwy 191 between mile marker 28.0 and 29.0 (figure 1).

Break-the-beam systems require a clear line of sight between a transmitter and its receiver. The maximum range of the transmitters is 402 m (1/4 mi). Thus, under ideal conditions, four sensor pairs (four detection zones) are needed to cover one mile on one side of the road. However, curves, slopes, and vegetation usually require additional sensors. The site along US Hwy 191 has a total of 15 detection zones (6 on the east side, 9 on the west side) (figure 1). The sensors are attached to metal or wooden poles, dependent on the total weight, size, and height of the equipment and poles. Poles with sensors are referred to as “stations.” A station typically has either two transmitters or two receivers, facing in opposite directions. There are nine transmitter stations, and nine receiver stations (figure 1). One of the receiver stations situated in the middle of the array (see figure 1) also serves as the master station (see later). Most of the metal and wooden poles are located in the clear zone, 1-8 m (3.3-26.3 ft) from the edge of the pavement. Metal posts have concrete foundations and a break-away system, while wooden poles are placed directly into the ground with three holes located in the pole just above ground level allowing them to break-away in case of a collision. Each station is powered by its own solar panels. In some cases, the solar panels are mounted on a separate post to avoid tree shade or to reduce weight and size for the pole with the sensors. Batteries provide power during periods of darkness or snow cover on the solar panels, and the battery charge is maintained by the solar panels.

Most of the sensors are mounted about 1.2 m (4 ft) above the ground as this system is designed to detect elk. However, some sensors are situated higher or lower to compensate for slopes, rises, and low areas in the right-of-way. The “beam” of microwave radio signals is relatively narrow (3°) when it leaves the transmitter, and becomes several meters (yards) wide farther from the transmitter. When an animal’s body breaks the beam in one of the detection zones, the receiver signal output is decreased, indicating a detection event. The receiver station then sends an UHF radio signal to the master station (see figure 1) to report the detection. Upon receiving the detection report, the master station sends a UHF signal to activate the flashing amber warning lights that are located on four of the stations (see figure 1).

When activated, the flashing lights alert the drivers that a large animal may be on or near the road at that time. There are four stations with warning lights: two for southbound traffic and two for northbound traffic (figure 1). The warning lights are accompanied by black-on-yellow warning signs that say “wildlife crossing,” “next 1 mile,” or “next ½ mile” when flashing. The system is programmed to activate the three warning lights that are closest to the zone in which the detection occurred. If no new detections occur, the warning lights are turned off after three minutes. If the signal in a detection zone is blocked continuously for more than 12 minutes the additional detections from that detection zone are ignored and the warning lights are deactivated, unless new detections are reported from other detection zones. Once the beam is no longer blocked, the detection zone concerned becomes active again.

Drivers are informed of the presence and function of the system by white on green information signs, one for each travel direction, about 322 m (0.2 mi) before the first station. The signs say “animal detection test section ahead.” In addition, there is another white-on-green information sign for each travel direction that says “end test section” at the last station. However, during the research period (26 January 2005–5 March 2005) the warning lights were left unplugged, and the warning signs were not attached; we wanted to have a thorough understanding of the reliability of the system before presenting drivers with warning lights and signs.

The system records all detections and saves them at the master station. Detection events are broadcast using the UHF radio system, in real-time, so that the animal detection system operation can be monitored on site using a portable data radio connected to a computer (e.g., laptop). The system also saves the date and time for each change in beam status (i.e., the beginning and end of a break-of-the-beam are recorded as two changes in beam status), the detection zone in which the detection occurred, and a code for the activation of the flashing warning signals. In addition, the logging system maintains and reports statistics associated with the operation of individual elements of the system.

These statistics include radio link failures, radio link signal levels, beam break summaries, and logging memory status. The data can be downloaded on-site (memory card, direct physical link to laptop, or radio link to laptop), or from a remote location through a modem and land-based phone line. When an animal crosses the road, it typically results in four records: two on each side of the road that mark the beginning and end of the break-of-the-beam. If the animal crosses the road straight, the detections occur in the zones that are on opposite sides of the road. Based on the location of the detection zones and the date and time stamp, one can determine the location, direction, and timing of the crossing event.

**Reliability**

**Data interpretation**

The detection data from 26 January 2005 until 5 March 2005 were extracted from the system. We interpreted the data patterns for three periods: 26 January 2005–14 February 2005, 18 February 2005–21 February 2005, and 25 February 2005–5 March 2005 (30 days total). We distinguished seven categories (table 2). Detections caused by researchers working at the field site were excluded from all analyses. Each “day” started and ended with the arrival of the researchers at the site (usually in the morning hours) or, if the researchers did not visit that day, a “day” started and ended at noon (12:00).

The interpretation of the data based on the detection patterns is at least partially subjective and subject to errors. This is particularly true for the category “unclear.” Although certain detections may seem random and do not seem to fit any particular pattern, they may very well be related to real-world events. For example, an animal walking in the right-of-way may trigger the system, but the animal may not cross the road and may not trigger the system on the other side. Alternatively, the animal may also cross the road much farther up or down the road, thus producing seemingly unrelated detections. In addition, the beam with the microwave signals is not at a constant height above the ground. Rises or low areas, slopes, and curves result in areas where the beam may shoot over an animal’s body or where it is very close to the ground (e.g., 45 cm (18 in)). Thus medium-sized mammals such as coyotes, but also relatively large mammals such as elk, may be detected in some areas and not in others, resulting in seemingly isolated and unrelated detections. Furthermore, traffic can also cause isolated detections, especially in detection zones 8, 9, and 1 where the beam is relatively close to the edge of the pavement (for location of the detection zones see figure 1). Thus, vehicles that drive on the edge of the pavement can also cause detections that may not fit any particular pattern, and these may be classified as “unclear” as well.

Table 2. Detection data categories

Category	Definition
Animal crossings	All detections that showed “something” crossed the road and triggered the system in detection zones on opposite sides of the road. This is synonymous with the term “crossing event”. Note: we included detections in the right-of-way that seemed to be related to the crossing (i.e. detections immediately before and after the crossing of the actual pavement).
Traffic/snowplow	A series of consecutive detections in adjacent sections with the direction of travel. The detections may be caused by snow spray from snow plows, signal reflections from large vehicles (buses/trailers) or vehicles driving close to the edge of the road.
Traffic Black Butte Ranch	All detections in detection zone 3 between 7:00-23:00 that had no match on the other side of the road.
Trailhead	All detections in detection zone 7 between 7:00-19:00 and that had no match on the other side of the road.
Error	Detections associated with a failed radio report or detections that occur simultaneously in adjacent sections.
Unclear	Detections that do not fall in any of the above categories and that cannot be readily explained based on the data patterns alone.

Other interpretation problems occur when several animals cross the beam at the same time, i.e., within two seconds of each other. These crossings will be recorded as one beam break event rather than several. Thus, the number of “animal crossings” or “crossing events” (see table 2) detected by the system can underestimate the actual number of animals that crossed the road. This is especially true for gregarious species, such as elk. This underestimation does not affect the functioning of the system, but it is one of the factors that complicate data interpretation.

#### *Snow tracking*

We conducted daily snow tracking sessions on both sides of the road for the full 1,609-m (1 mi) road length covered by the animal detection system for three periods: 26 January 2005–14 February 2005, 18 February 2005–21 February 2005, and 25 February 2005–28 February 2005. The visits were mostly conducted in the morning hours. On the first day of each session we did not record any tracks, rather only erased all tracks present in the snow with a rake. Thus, there were 25 days of snow tracking in total. On the following days for each session, we recorded and erased all new tracks of large animals that crossed in between the transmitters and receivers of the animal detection system since the last visit. When an animal appeared to have crossed the road we specifically looked for a matching track on the other side of the road. The snow track data were compared to the detection data saved by the animal detection system to further investigate system reliability.

Snow tracking is not without error either. In our area snow tracks may have been covered by fresh snow, snow spray from snow plows, or the wind may have caused snow to fill in the tracks. Snow tracks may also have disappeared or faded as a result of snow melt, or the snow may have disappeared altogether in certain areas, especially on the west and south facing slopes of the road bed. In addition, some animals may not have left tracks when there was a hard icy crust on top of the snow. Furthermore, the direction of travel of the animal may have been misinterpreted because of unclear snow tracks, and the number of animals traveling in a group and animals that step in each others tracks may have been miscounted or improperly estimated. Finally, some tracks may have been simply overlooked. In some cases, such tracks may have been identified the next day; in other cases, they may never have been identified.

#### *Blind spots*

Blind spots are areas within the road section equipped with the system where large animals may pass between sensors without being detected. We tested for such potential blind spots by using a human (170 cm (5 ft 7 in)) as a model for elk. We passed through the detection zones at 20-m (21.9 yard) intervals on 5, 7, and 13 February 2005. We recorded the location and time of each passage and compared these notes with the detections recorded by the system. We walked well past the detection zone and allowed for a minimum of three minute intervals between consecutive passages to avoid desensitization of the beam. Locations on which the system failed to pick up the model were identified as “blind spots.”

#### *Reliability norms*

In the previous sections we described the different methods used to investigate system reliability. However, we must also define what we consider reliable. For this study, we used a range of parameters to describe how reliable we found the animal detection system to be (table 3). First, we found it important that “crossing events” (see earlier) could be identified in the detection data (through data interpretation) and that the system was able to detect large animals continuously during the period investigated without abundant false detections generated by the system (based on data interpretation). We also found it important that the timing and direction of travel for crossing events would match local knowledge about the behavior of large animals in the area, specifically elk. Furthermore, we wanted to see that elk crossings recorded through snow tracking could be linked to a crossing event detected by the system. We wanted to see this percentage be at least 80 percent, and preferably 100 percent. Therefore, we defined different levels of reliability for this quantitative parameter (see table 3). Finally, we found it important that the system not have blind spots where it would fail to detect a large animal approaching the road.

Table 3. Parameters and definition for reliability norms

Parameter	Definition
Crossing events	Reliable: crossing events can be identified through interpretation of the data patterns.
	Unreliable: crossing events cannot be identified through interpretation of the data patterns.
System failures	Reliable: the system is able to detect large animals continuously during the period investigated without abundant false detections generated by the system or system failures (based on data interpretation).
	Unreliable: the system is not able to detect large animals continuously during the period investigated or abundant false detections are generated by the system or the system experienced general failures (based on data interpretation).
Local knowledge	Reliable: the crossing events match local knowledge about the behavior of large animals, especially elk.
	Unreliable: the crossing events do not match local knowledge about the behavior of large animals, especially elk.
Snow tracking	Absolute reliability: 100% of the elk crossings recorded through snow tracking can be linked to crossing events detected by the system.
	High reliability: 80%-99% of all elk crossings recorded through snow tracking can be linked to crossing events detected by the system.
	Medium reliability: 60%-79% of all elk crossings recorded through snow tracking can be linked to crossing events detected by the system.
	Low reliability: <60% of all elk crossings recorded through snow tracking can be linked to crossing events detected by the system.
Blind spots	Reliable: there are no blind spots in the road section equipped with the system.
	Unreliable: there are blind spots in the road section equipped with the system.

The warning signs and lights were not visible to the public during our study period. However, we were able to quantify how long the lights would have been activated given the number and timing of the recorded detections. In addition, the detection data were used to evaluate how long the warning lights should be activated after a detection occurs.

*Activation period per day*

We counted the number of detections, regardless of the potential cause, for each day between 26 January 2005–14 February 2005, 18 February 2005–21 February 2005, and 25 February 2005–5 March 2005 (30 days total). We also calculated the detection intervals (i.e., the time elapsed between consecutive detections). The number of detections per day, the detection intervals, and the three-minute activation periods (see “animal detection system”) allowed us to calculate the total period per day for which the warning signs would have been activated in order to evaluate whether the system’s real time warnings were more dynamic and different from permanent warning signs that drivers may habituate to and that are not considered very effective (e.g., Pojar et al. 1975, Sullivan and Messmer 2003).



### Activation period after a detection

Even though the warning lights were unplugged and even though the warning signs were not attached during the study period, the system was initially programmed to activate the warning lights for three minutes after a detection occurred (see also “animal detection system”). If a new detection occurred before the three minutes had passed, e.g., after one minute and 45 seconds, then the warning light clock started again, leaving the warning lights activated for an additional three minutes. In this example, the warning lights would have been activated for four minutes and 45 seconds total.

The three-minute activation period was based on best professional judgment, as we did not know how long it would take large animals (especially elk) to cross the road or how frequently they would be detected during such a crossing. However, we did know we wanted the warning lights to remain active while the animal (elk) was still in the process of crossing the road, and we also knew we did not want to present drivers with activated warning lights longer than required. Keeping the warning signals on for a long time after a detection may jeopardize driver confidence in the system, as the animals may no longer be visible in the immediate vicinity of the road, hence increasing the likelihood that drivers will ignore the warnings signals the next time they pass through a road section equipped with the system.

Thirty days of detection data were used to calculate the duration of crossing events (based on data interpretation, see “data interpretation”) and the detection intervals for these crossing events (26 January 2005–14 February 2005, 18 February 2005–21 February 2005, and 25 February 2005–5 March 2005). These data provided us insight into the optimal activation period for the warning lights when a detection occurs.

## Results

### Reliability

#### Data interpretation

A scan of all the detection data showed no indication of “down time” for the animal detection part of the system between 26 January 2005 and 5 March 2005. The number of detections per day did not show a consistent increase or decrease in the periods investigated (figure 2). However, the number of detections was relatively high on 5-14 February and on 3-4 March 2005. The total number of detections per day varied between 16 and 139, with a median of 47 detections per day (figure 2).

Almost 47 percent of all detections were classified as crossings, 25 percent were classified as unclear, and 14 percent were classified as traffic on the Black Butte Ranch access road (figure 3). A small number of the detections (0.3%) seemed to be related to hikers or skiers at the trailhead in detection zone 7 (for location see figure 1). During the periods investigated, nine percent of all detections were classified as caused by snow plows or other traffic, and five percent of all detections were classified as errors.

The detection data that were classified as animal crossings were split into west- and eastward movements, based on which side of the road the movement was first and last detected. Then the detection data were grouped per hour (figure 4). Most of the westward movements occurred between 22:00 and 5:00 with a peak between 1:00-2:00. Most of the eastward movements occurred between 1:00 and 8:00 with a peak between 6:00 and 8:00.

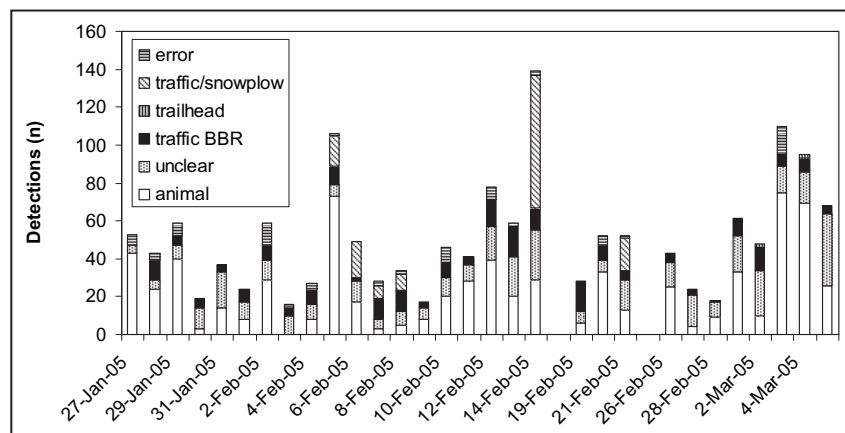

Figure 2. The number of detections per day between 26 January 2005 and 14 February 2005, 18 February 2005 and 21 February 2005, and 25 February 2005 and 5 March 2005.

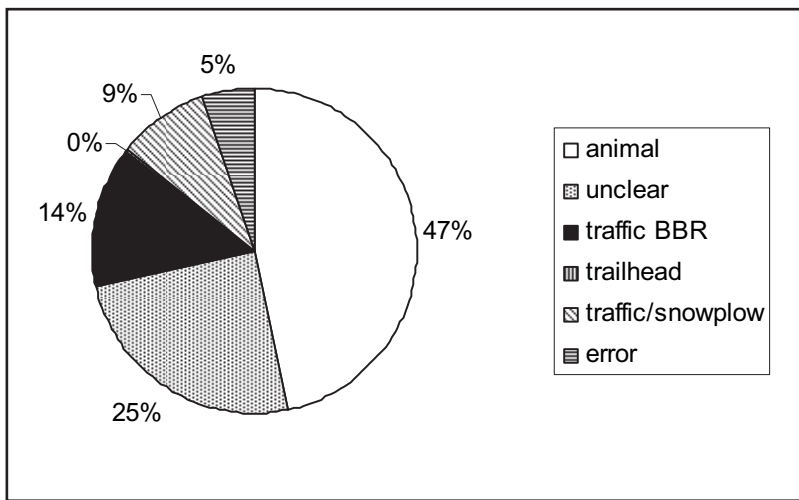

Figure 3. The percentage of detections per category (n total = 1533) between 26 January 2005 and 14 February 2005, 18 February 2005 and 21 February 2005, and 25 February 2005 and 5 March 2005.

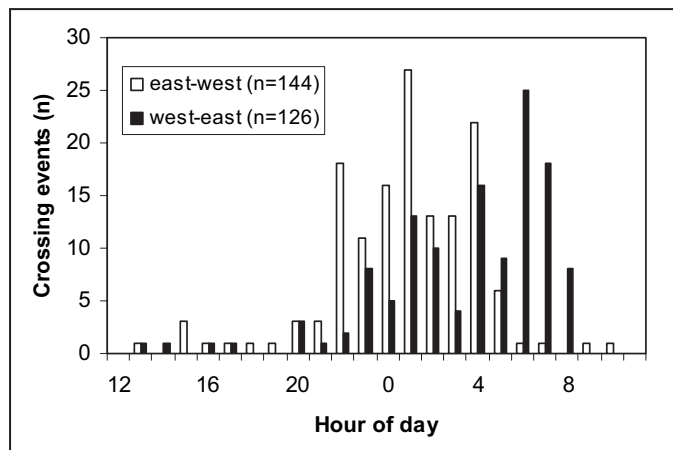

Figure 4. The number of crossing events detected by the system per hour of day for east and westward movements between 26 January 2005 and 14 February 2005, 18 February 2005 and 21 February 2005, and 25 February 2005 and 5 March 2005.

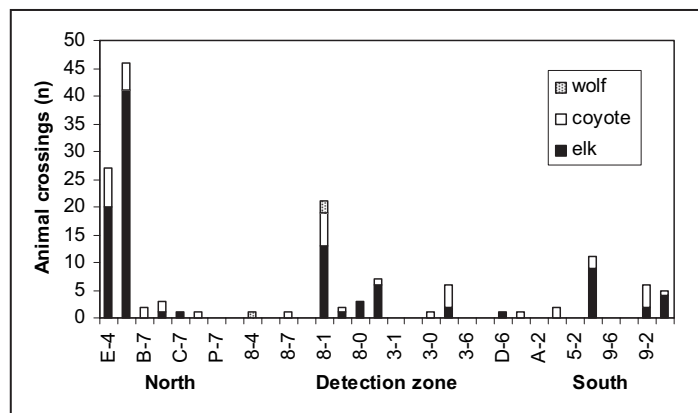

Figure 5. The number of recorded crossings for elk, coyote and wolf through snow tracking between 26 January 2005 and 14 February 2005, 18 February 2005 and 21 February 2005, and 25 February 2005 and 28 February 2005. See figure 1 for the exact location of the detection zones.

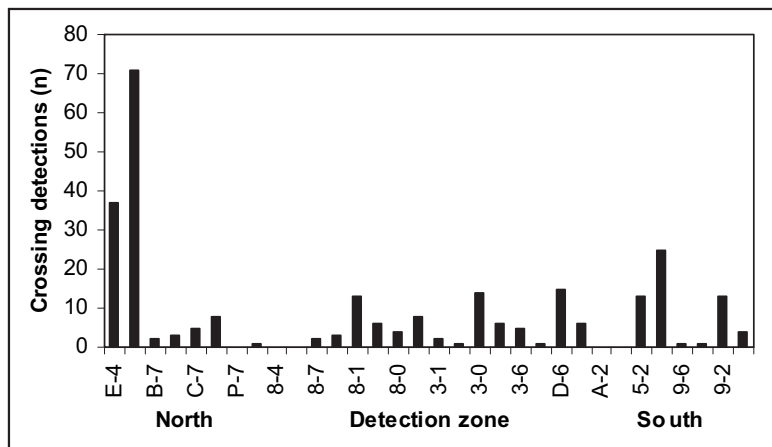

Figure 6. The number of crossings based on interpretation of the detection data between 26 January 2005 and 14 February 2005, 18 February 2005 and 21 February 2005, and 25 February 2005 and 28 February 2005. See figure 1 for the exact location of the detection zones.

### Snow tracking

Within the investigated period we encountered the tracks of three medium or large mammal species. We only counted clear animal crossings characterized by snow tracks approaching and leaving the road on opposite sides. Tracks indicating clear crossing were encountered for the following species: elk (n=104), coyote (n=41), and wolf (n=3).

For an overall comparison of the spatial distribution between the detection data and the snow tracking data we plotted the animal crossings recorded through snow tracking for each detection zone combination (figure 5), and we did the same for the crossing events recorded by the system (figure 6). The pattern of crossing frequencies for the different detection zone combinations was similar for the detection and snow tracking data, especially for elk. Most crossings occurred between detection zones E and 4 on the north end of the road section covered by the system. The snow tracking data confirmed that it is mostly elk that crossed the road there. Coyotes crossed throughout the road section covered by the system, while the limited number of wolf crossings all occurred in detection zone 8 (see figure 1 for location).

A day-by-day and detection zone-by-detection zone comparison showed that 87 percent of all recorded elk crossings and 2 percent of all recorded coyote crossings were detected by the system (table 4). However, some elk crossings were not detected by the system (table 5). In addition, not all crossing detections by the system could be confirmed through snow tracking. Matching snow tracks were found in only 38.4 percent of all crossing detections (56 out of 146).

Table 4. The number of recorded crossings for elk, coyote and wolf through snow tracking between 26 January 2005 and 14 February 2005, 18 February 2005 and 21 February 2005, and 25 February 2005 and 28 February 2005, and the number and percentage of these crossings detected by the animal detection system

Species	Snow track crossings (n)	Detected (n)	Detected (%)
Elk ( <i>Cervus elaphus</i> )	104	90	86.5
Coyote ( <i>Canis latrans</i> )	41	1	2.4
Wolf ( <i>Canis lupus</i> )	3	0	0

Table 5. The detection zones where elk crossings were recorded through snow tracking but not by the system, between 26 January 2005 and 14 February 2005, 18 February 2005 and 21 February 2005, and 25 February 2005 and 28 February 2005

Detection zones	Direction of travel	Snow track crossings (n)	Detection zones	Direction of travel	Snow track crossings (n)
0-8	East-west	5	1-8	East-west	1
8-1	West-east	4	4-E	East-west	1
0-3	East-west	2	7-B	East-west	1

**Blind spots**

The animal detection system detected the human model on most locations in most detection zones (figures 7 and 8). However, there was a very substantial blind spot in detection zone 8, and to a lesser extent in detection zones B, 0, 3, 6 D, 5, 2 and 9 (see figure 1 for location), potentially 17.8 percent of the total length covered by the sensors.

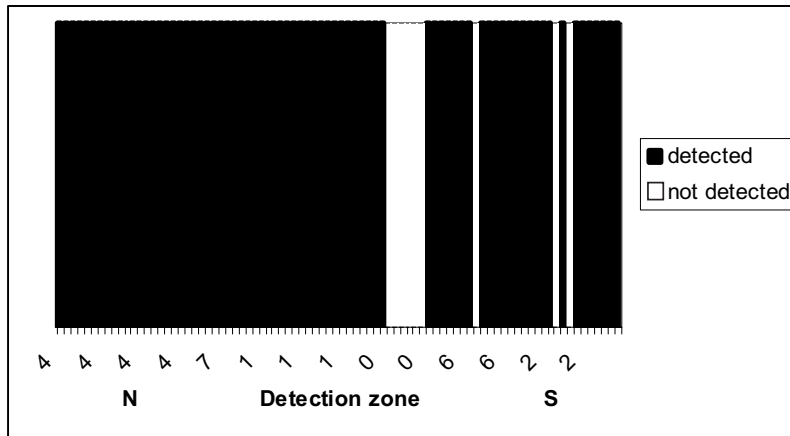

Figure 7. Blind spots of the detection zones on the east side of the road (compare to figure 1 for exact location).

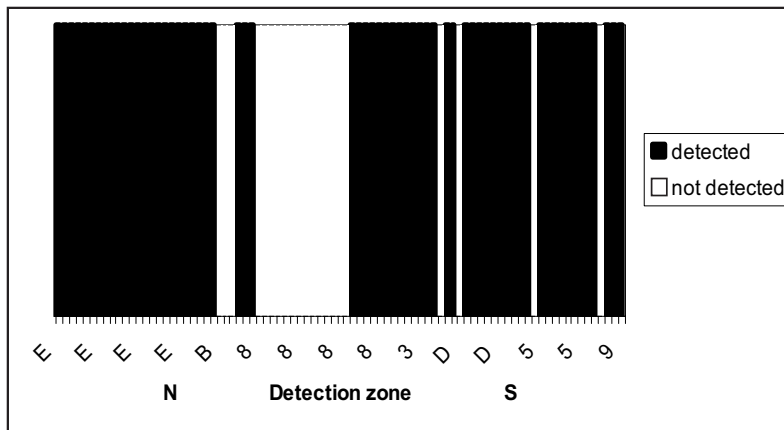

Figure 8. Blind spots of the detection zones on the west side of the road (compare to figure 1 for exact location).

**Reliability norms**

The system was found to be reliable with regard to the presence of clear crossing events in the detection data, the absence of indication of system failures, and the match between the timing and direction of the crossing events and local knowledge about the behavior of the elk (table 6). In addition, the system was found to be highly reliable with regard to the percentage of elk crossings detected by the system (87%); however, the reliability with regard to this parameter was not absolute. Finally, the system was found to be unreliable with regard to the presence of blind spots.

Table 6. Reliability evaluation of the animal detection system

Parameter	Definition
Crossing events	Reliable: crossing events could be identified through interpretation of the data patterns.
System failures	Reliable: the system was able to detect large animals continuously during the period investigated without abundant false detections generated by the system or system failures (based on data interpretation).
Local knowledge	Reliable: the crossing events matched local knowledge about the behavior of large animals, especially elk.
Snow tracking	Highly reliable: 87% of all elk crossings recorded through snow tracking could be linked to crossing events detected by the system.
Blind spots	Unreliable: there were blind spots in the road section equipped with the system.

## Warning signs

### Activation period per day

The flashing warning lights were programmed to flash for three minutes after the last detection. If we assume that there was at least a three-minute interval between consecutive detections, the flashing warning lights would have been activated for 141 minutes (2:21 h) on a day with 47 detections (see figure 2). However, most detections were highly clustered and had much shorter time intervals between them (figure 9). The median interval between consecutive detections was one minute and 33 seconds, resulting in 73 minutes (1 h 13 min) of activated warning lights on a day with 47 detections.

### Activation period after a detection

Most crossing events (72.6%) took less than three minutes to complete (from the first to the last detection), but some crossing events took much longer (figure 10). In addition, crossing events involving multiple individuals (based on the patterns in the detection data) tended to take longer than crossing events that suggested that only one individual crossed. However, it is quite possible that the latter category could have included crossing events where multiple individuals traveled close together, as these would have only caused one detection on each side of the road. Overall, the median duration of a crossing event was one minute and 29 seconds.

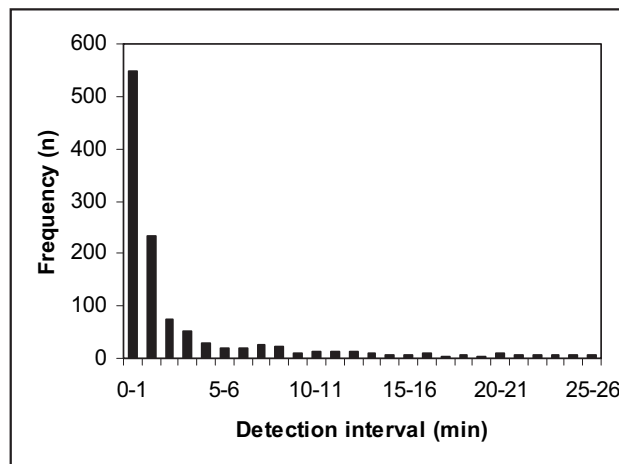

Figure 9. The frequency distribution of the detection interval between consecutive detections for the detections between 27 January 2005 and 14 February 2005, 19 February 2005 and 21 February 2005, and 26 February 2005 and 5 March 2005. Note: the graph was cut off at 25 min; the longest detection interval was 17 h 39 min.

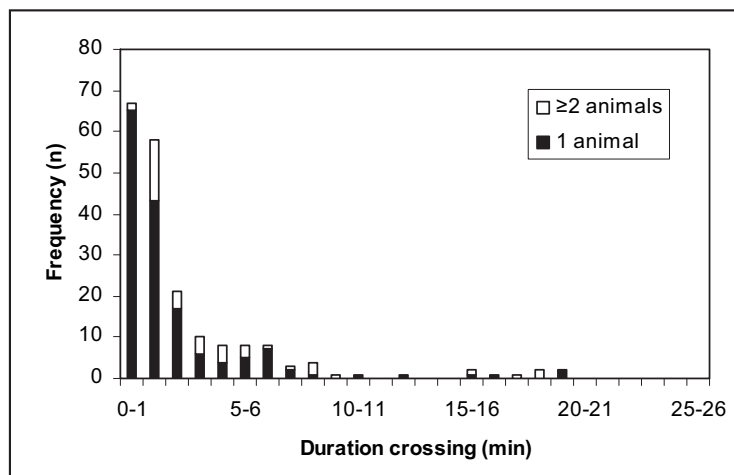

Figure 10. The frequency distribution of the duration of crossing events between 27 January 2005 and 14 February 2005, 19 February 2005 and 21 February 2005, and 26 February 2005 and 5 March 2005. Note: the graph was cut off at 25 minutes; the longest duration of a crossing event was 1 h 10 min.

Most detection intervals (65.7%) for crossing events were less than one minute (figure 11). The median detection interval was 38 seconds. The line representing the cumulative percentage of the detection intervals (figure 11) indicates that 88.1 percent of all detection intervals for crossing events would be covered if the warning lights remain activated for three minutes after the last detection. Should the warning lights remain active for four minutes after the

last detection, this percentage would increase only slightly from 88.1 to 90.8 percent. However, decreasing the warning period to two minutes would result in a more substantial change from 88.1 to 81.8 percent.

We also categorized each crossing event based on the longest detection interval for each crossing, and how long of a warning period (in minutes) after a detection would have been required to keep the warning lights continuously activated while the crossing event was still in process (figure 12). For example, if the longest detection interval during a crossing event was two minutes and 41 seconds, then a three-minute warning period would have been required to prevent the warning lights from having turned off before the crossing event was completed. With a three-minute warning period, 78.1 percent of all crossing events would have had the warning lights continuously activated during the crossing event (figure 12). Increasing the warning period to four minutes would result in a slight increase from 78.1 to 82.6 percent. However, decreasing the warning period to two minutes would result in a more substantial change from 78.1 to 68.2 percent.

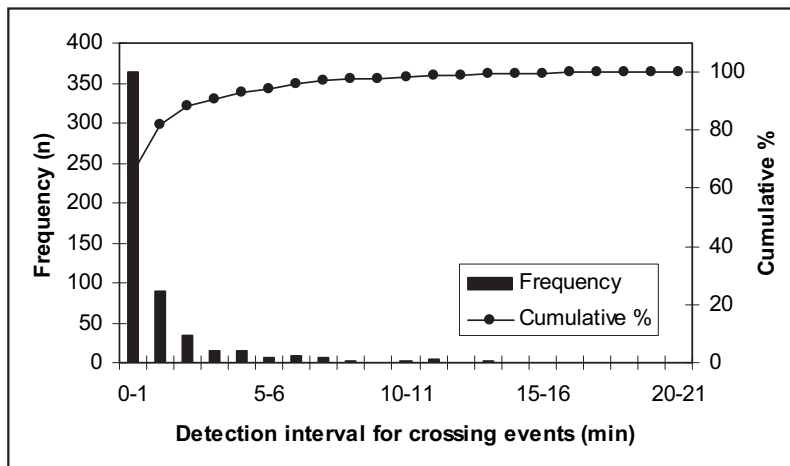

Figure 11. The frequency distribution of the detection interval between consecutive detections for the crossing events between 27 January 2005 and 14 February 2005, 19 February 2005 and 21 February 2005, and 26 February 2005 and 5 March 2005. The line represents the cumulative percentage of all detection intervals (see text).

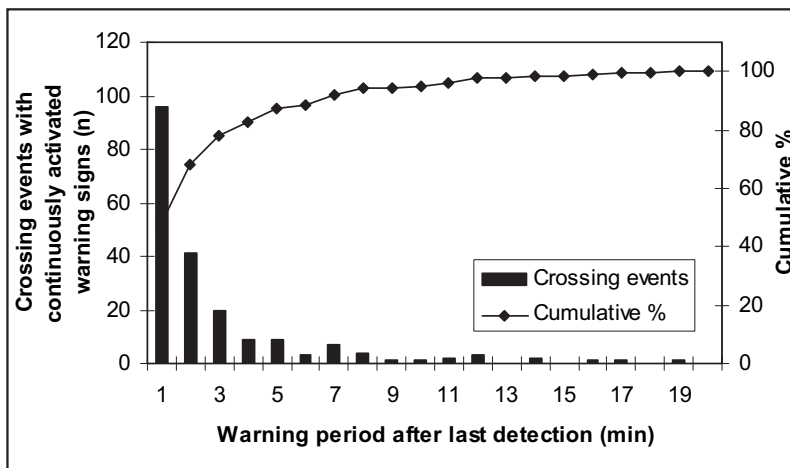

Figure 12. The number of crossing events with continuously activated warning signs (warning lights remain active during the entire crossing event) given a certain warning period after the last detection. The results are based on the crossing events between 27 January 2005 and 14 February 2005, 19 February 2005 and 21 February 2005, and 26 February 2005 and 5 March 2005. The line represents the cumulative percentage of all crossing events (see text).

## Discussion

### Reliability

The patterns in the detection data indicated that at least 47 percent of all detections were related to animals crossing the road. However, it is likely that some of the detections currently classified as “unclear” were also related to animal movements. Therefore, the 47-percent value should be seen as a minimum estimate. The percentage of suspicious detections, potential system-generated errors, was estimated at five percent and was mostly due to failed radio reports

from detection zone 5 and 9 (see figure 1 for location). The station that has the receivers for these two detection zones may suffer from a lack of a straight line of sight with the master station and signal reflection off a rocky slope. However, within the investigated periods there was no indication of a high number of highly suspicious detections or false detections generated by the system. The system seems to have been detecting animals between 26 January 2005 and 5 March 2005 without system failures, and the system seems to have been stable during this period.

The distribution of detected animal crossings over the day and the direction of travel matched local knowledge about the behavior of the elk herd (see methods). The elk usually spend the day on the forested slopes. In the evening the elk travel down the slopes and cross the road to feed on the grasses and shrubs in the valley bottom. In the morning they leave the valley bottom, cross the road, and travel up the forested slopes. The match between the patterns in the detection data and local knowledge seems to confirm that the system is able to detect large animals, specifically elk. In addition it suggests a correct interpretation of the detection data and a correct identification of crossing events.

The number of detected crossing events for each detection zone combination matched the number of recorded elk crossings through snow tracking closely. Detection zones E and 4 (see figure 1 for location) had cover close to the road and were by far the most heavily used zones by elk when they cross the road. This is also where the majority of all crossing events were detected by the system. Again, this seems to confirm the ability of the system to detect elk, and it also suggests a correct interpretation of the detection data.

Almost 87 percent of all elk crossings recorded through snow tracking could be linked to a crossing event detected by the system. Assuming that the crossings detected by the system are indeed caused by animals, 38 percent of these detected crossings were confirmed through snow tracking. These percentages, especially the second one, may not seem high or high enough, but there are errors associated with both interpretation of detection data and with snow tracking (see methods). These percentages also suggest that elk or other large mammals crossing the road may be more reliably identified through interpretation of the detection data than through snow tracking, at least under the conditions that were present at the study site (see methods). Medium-sized mammal species, such as coyotes and wolves, were not or rarely detected by the system.

The system detected a human model passing through the detection zones on most locations. However, we identified a substantial blind spot in detection zone 8 and to a lesser extent in detection zones B, 0, 3, 6, D, 5, 2 and 9 (see figure 1 for location), potentially 17.8 percent of the total length covered by the sensors. The blind spots in detection zones 8, B, 3, and D are the result of curves and slopes that make the beam shoot over the head of the model in some areas. The blind spots in detection zones 5 and 9 may be related to radio failures rather than true blind spots. The blind spots in detection zones 0, 6, and 2 require additional investigation, as the terrain seems relatively level and straight. It is not unlikely that the detections missed in detection zones 0, 6, and 2 were the result of desensitization of the beam; they may not be true blind spots. Nevertheless, the test indicated that the system should be able to detect elk passing through the detection zones on most locations, especially where they cross most frequently (detection zones E and 4).

The presence and location of blind spots in the system, especially in detection zones 8 and B, may also explain why some of the elk crossings were not detected by the system. Indeed, 11 of the 14 elk crossings that were not detected by the system were located in detection zones 8 or B. This suggests that the 87-percent detection rate for elk (see earlier) could be substantially higher (up to 97%) if the blind spots of detection zones 8 and B are addressed.

### **Warning signs**

The total time that the flashing warning lights would be activated for was one hour and 13 minutes per day, based on a median of 47 detections per day and a median detection interval of one minute and 33 seconds. This is a marked difference with permanently activated warning signs, which tend to be ignored by drivers. The real-time activation of the warning lights after a detection could potentially lead to increased driver response.

Most crossing events (72.6%) were completed within three minutes, and the median duration of a crossing event was one minute and 29 seconds. The interval between the detections that occurred during a crossing event was typically less than one minute (65.7%), with a median of 38 seconds. However, longer detection intervals did occur, and “only” 88.1 percent of all detection intervals for crossing events would be covered if the warning signs are activated for three minutes after the last detection. With a three-minute warning period after the last detection, 78.1 percent of all crossing events would have had the warning lights continuously activated during the crossing event. One may be tempted to increase the duration warning time from three to, for example, four minutes, but this would only result in a marginal improvement in coverage of the detection intervals for crossing events (2.7%) and the number of crossing events with continuously flashing lights (4.5%), while making the warning signals substantially less time specific (an increase in warning period after the last detection of 33.3%).

### **Conclusion**

The patterns in the detection data suggest that most detections by the system were probably related to real-world events and that at least half of all detections appear to be related to large animals, specifically elk, approaching or leaving the road. In addition, the patterns in the detection data show no indication of system failures or abundant false detections, the crossing events detected by the system match local knowledge about the behavior of the elk, the spatial distribution of the elk crossings observed through snow tracking matches that of the crossing detections, and

a high percentage of all elk crossings observed through snow tracking could be linked to crossing events detected by the system. We conclude that the system detects large animals reliably. However, depending on the location, and potentially also depending on the conditions (e.g., weather), the system does not detect all large animals that approach or leave the road.

We also conclude that the total period of time per day for which the warning lights would be activated is relatively short, especially when compared to permanently activated warning signs, potentially resulting in increased driver response. Furthermore, the three-minute period for which the warning lights are activated after a detection appears to be a good balance between keeping the warning lights on while the animal (elk) is still in the process of crossing the road, and not presenting drivers with activated warning lights longer than necessary.

Despite our conclusions, we recognize that other researchers or transportation agencies may want to evaluate additional or different reliability parameters than those used for this study. We also recognize that others may want to see a higher or lower level of reliability for an animal detection system, especially in relation to potential liability issues in case of an accident. In addition, we realize that it is up to the responsible transportation agency to decide what the optimal warning period for an animal detection system should be.

## **Recommendations**

Even though we concluded that this animal detection system appears to detect elk reliably, there are blind spots in the system as a result of design errors. For future projects we recommend that the location of the posts and sensors, especially at curves or slopes, are carefully evaluated to ensure that the detection beam stays close enough to the ground to be able to detect the target species. However, even if the location of poles and sensors is carefully evaluated, one should never assume that an animal detection system detects *all* animals that approach or cross the road under *all* circumstances. Therefore, one should avoid the use of warning signs that suggest that elk are only present on or near the road when the warning signals are activated. Instead, we suggest using signs that urge drivers to increase their alertness (see Katz et al. 2003), indicating that drivers should always be alert and that they should always be prepared to stop for large animals on or near the road, regardless of whether the warning signs are activated.

We also recommend that the blind spots in detection zones 8 and B (see figure 1) are addressed through the installation of additional posts and sensors. Furthermore, we recommend a further evaluation of the blind spots in the other detection zones to evaluate whether they are real and how short (isolated) blind spots may be addressed. Furthermore, the number of unsuccessful radio contacts for some stations should be reduced (especially for detection zones 5 and 9, see figure 1), either by moving the master station to the west side of the road or through more fundamental changes to the communication system.

The following recommendations are based on experiences that were not reported in this manuscript. However, we do feel that they are important, as they relate to the reliability and robustness of the system. We learned that the brackets that hold the sensors in place can break as a result of extreme temperature fluctuations. These brackets should be secured or replaced to avoid potential false detections or system downtime. In addition, periodic vegetation management is required. High, wet, and moving vegetation can result in false detections, they can cause a serious reduction in signal strength, and they may result in the temporary deactivation of the detection zone concerned.

Furthermore, we recommend developing standards for the reliability of animal detection systems, and we encourage the testing of other animal detection system technologies from various manufacturers. We also suggest investigating the effectiveness of a variety of warning signs and signals with regard to driver response and potential liability for transportation agencies in case of an accident. Despite the encouraging results from Swiss research (Kistler 1998, Romer and Mosler-Berger 2003, Mosler-Berger and Romer 2003), more and better data are required on the effectiveness of animal detection systems, especially with respect to the potential reduction in animal-vehicle collisions. We also recommend keeping log books to document the operation and maintenance costs of animal detection systems. Finally, we recommend miniaturization of animal detection systems to address landscape aesthetics concerns and safety issues for equipment placed in the right of way.

**Acknowledgements:** We would like to thank the agencies that funded this study: the Federal Highway Administration (FHWA) and 15 departments of transportation – Alaska Department of Transportation and Public Facilities, and the departments of transportation of California, Indiana, Iowa, Kansas, Maryland, Montana, Nevada, New Hampshire, New York, North Dakota, Oregon, Pennsylvania, Wisconsin, and Wyoming. Other funds were received from the Western Transportation Institute at Montana State University (U.S. Department of Transportation University Transportation Center funds). In addition, we would like to thank Yellowstone National Park for hosting the system, and Duncan and Eva Patten, and Greg and Sara Knetge of the Black Butte Ranch for their help, advice, and hospitality.

**Biographical Sketches:** Dr. Marcel P. Huijser received his M.S. in population ecology (1992) and his Ph.D. in road ecology (2000) at Wageningen University in Wageningen, The Netherlands. He studied plant-herbivore interactions in wetlands for the Dutch Ministry of Transport, Public Works and Water Management (1992-1995), hedgehog traffic victims and mitigation strategies in an anthropogenic landscape for the Dutch Society for the Study and Conservation of Mammals (1995-1999), and multifunctional land use issues on agricultural lands for the Research Institute for Animal Husbandry at Wageningen University and Research Centre (1999-2002). Currently Marcel works on wildlife-transportation issues for the Western Transportation Institute at Montana State University (2002-present). He is a member of the Transportation Research Board (TRB) Task Force on Ecology and Transportation and co-chairs the TRB Subcommittee on Animal-Vehicle Collisions.



Whisper Camel obtained her B.S. in wildlife biology from the University of Montana in Missoula, MT (2003). She was awarded a fellowship by the Western Transportation Institute at Montana State University (WTI-MSU) and the Wildlife Conservation Society (WCS) to help investigate wildlife-transportation interactions on US Hwy 93 in western Montana. Whisper is currently working on her M.S. in ecology - fish and wildlife management at Montana State University in Bozeman, MT. Her research focuses on road and land cover characteristics that are associated with deer-vehicle collisions along US Hwy 93 on the Flathead Indian Reservation in western Montana.

Amanda Hardy obtained her B.S. in biology - fish and wildlife management in 1997 and an M.S. in ecology - fish and wildlife management in 2001 at Montana State University, Bozeman, MT. She began studying transportation and wildlife interactions in 1998 with the initiation of her research thesis assessing bison and elk behavioral and stress hormone responses to winter recreation in Yellowstone National Park. Amanda joined WTI-MSU in 2001 and helped to develop the wildlife and transportation program into one of WTI-MSU's focus research areas. Her current work relates to the evaluation of wildlife crossing structures and driver responses to wildlife warning signs, as well as methods to analyze animal-vehicle collision data. She is also serving as a facilitator of an interagency effort to develop an ecosystem approach to mitigation of the highway program impacts on ecosystem processes. Amanda has served on the planning committee of the 2003 and 2005 International Conferences on Ecology and Transportation and was a co-organizer of the Wildlife Crossing Structure Field Course in Banff National Park, Alberta, Canada, in September 2002. Ms. Hardy is an appointed member of the Transportation Research Board's (TRB) Task Force on Ecology and Transportation, co-chairs the TRB Animal-Vehicle Collisions Subcommittee, and acts as a liaison between these groups and other TRB affiliates including the TRB Environmental Analysis in Transportation Committee.

## References

- Gordon, K., S.H. Anderson, B. Gribble, M. Johnson. 2001. Evaluation of the FLASH (Flashing Light Animal Sensing Host) system in Nugget Canyon, Wyoming. Wyoming Cooperative Fish and Wildlife Research Unit. University of Wyoming, Laramie, WY, USA.
- Gunther, K.A., M.J. Biel, and H.L. Robison. 1998. Factors influencing the frequency of road-killed wildlife in Yellowstone National Park. In: G.L. Evink, P. Garrett, D. Zeigler, and J. Berry (eds). Proceedings from the International Conference on Wildlife Ecology and Transportation. FL-ER-69-98, Florida Department of Transportation, Tallahassee, Florida, USA.
- Huijser, M.P. and P.T. McGowen. 2003. Overview of animal detection and animal warning systems in North America and Europe. Pages 368-382 in: C.L. Irwin, P. Garrett, and K.P. McDermott (eds.). *Proceedings of the 2003 International Conference on Ecology and Transportation*. Raleigh, NC: Center for Transportation and the Environment, North Carolina State University, USA. Also available from the internet. URL: <http://www.icoet.net>
- Huijser, M.P. and P.T. McGowen. In prep. Overview of experiences with installation, operation and maintenance of animal detection systems throughout North America and Europe. In: M.P. Huijser (ed.). *Animal vehicle crash mitigation using advanced technology*. Western Transportation Institute - Montana State University, Bozeman, MT, USA.
- Katz, B.J., G.K. Rousseau, and D.L. Warren. 2003. Comprehension of warning and regulatory signs for speed. *Proceedings 73rd Institute of Transportation Engineers (ITE) Annual Meeting and Exhibit*, August 24-27, 2003, Seattle, WA, USA.
- Kinley, T.A., N.J. Newhouse & H.N. Page. 2003. Evaluation of the Wildlife Protection System Deployed on Highway 93 in Kootenay National Park During Autumn, 2003, November 17, 2003. Sylvan Consulting Ltd., Invermere, British Columbia, Canada.
- Kistler, R. 1998. Wissenschaftliche Begleitung der Wildwarnanlagen Calstrom WWA-12-S. Juli 1995 - November 1997. Schlussbericht. Infodienst Wildbiologie & Oekologie, Zürich, Switzerland.
- Mosler-Berger, Chr. and J. Romer. 2003. Wildwarnsystem CALSTROM. *Wildbiologie* 3: 1-12.
- Pojar, T.M. R.A. Prosenice, D.F. Reed and T.N. Woodard. 1975. Effectiveness of a lighted, animated deer crossing sign. *Journal of Wildlife Management* 39: 87-91.
- Romer, J. and Chr. Mosler-Berger. 2003. Preventing wildlife-vehicle accidents. The animal detection system CALSTROM: 3 p. Proceedings of Infra Eco Network Europe (IENE) conference. Habitat fragmentation due to Transport Infrastructure and Presentation of the COST 341 action, 13 - 15 November 2003, Brussels, Belgium. CD-ROMs with the proceedings can be ordered from the internet. URL: <http://www.iene.info/>
- Salsman, L.N. and T.B. Wilson. In prep. Case Studies: post installation modifications to the Animal Detection System in Montana. In: M.P. Huijser (ed.). *Animal vehicle crash mitigation using advanced technology*. Western Transportation Institute - Montana State University, Bozeman, MT, USA.
- Sullivan, T.L. and T.A. Messmer. 2003. Perceptions of deer-vehicle collision management by state wildlife agency and department of transportation administrators. *Wildlife Society Bulletin* 31: 163-173.
- White, P.J. and R.A. Garrott. 2005. Yellowstone's ungulates after wolves - expectations, realizations, and predictions. *Biological Conservation* 125: 141-152.